

# Communications Systems

Fiber Optic Communications

F.A.C.E.T.<sup>®</sup>  
by  
A

Student Workbook



3091584000311

Edition 4 91584-00

**FOURTH EDITION**

**First Printing, November 2003**

**Copyright September, 2003 Lab-Volt Systems, Inc.**

---

All rights reserved. No part of this publication may be reproduced, stored in a retrieval system, or transmitted in any form by any means, electronic, mechanical, photocopied, recorded, or otherwise, without prior written permission from Lab-Volt Systems, Inc.

Information in this document is subject to change without notice and does not represent a commitment on the part of Lab-Volt Systems, Inc. The Lab-Volt® F.A.C.E.T.® software and other materials described in this document are furnished under a license agreement or a nondisclosure agreement. The software may be used or copied only in accordance with the terms of the agreement.

ISBN 0-86657-309-7

---

Lab-Volt® and F.A.C.E.T.® logos are trademarks of Lab-Volt Systems, Inc.

All other trademarks are the property of their respective owners. Other trademarks and trade names may be used in this document to refer to either the entity claiming the marks and names or their products. Lab-Volt System, Inc. disclaims any proprietary interest in trademarks and trade names other than its own.

## Lab-Volt License Agreement

By using the software in this package, you are agreeing to become bound by the terms of this License Agreement, Limited Warranty, and Disclaimer.

**This License Agreement constitutes the complete agreement between you and Lab-Volt. If you do not agree to the terms of this agreement, do not use the software. Promptly return the F.A.C.E.T. Resources on Multimedia (CD-ROM) compact discs and all other materials that are part of Lab-Volt's F.A.C.E.T. product within ten days to Lab-Volt for a full refund or credit.**

**1. License Grant.** In consideration of payment of the license fee, which is part of the price you paid for this Lab-Volt product, Lab-Volt, as Licensor, grants to you, the Licensee, a nonexclusive, nontransferable license to use this copy of the CD-ROM software with the corresponding F.A.C.E.T. Lab-Volt reserves all rights not expressly granted to the Licensee.

**2. Ownership.** As the Licensee, you own the physical media on which the CD-ROM is originally or subsequently recorded or fixed, but Lab-Volt retains title to and ownership of the software programs recorded on the original compact disc and any subsequent copies of the CD-ROM, regardless of the form or media in or on which the original and other copies may exist. This license is not a sale of the original software program of Lab-Volt's CD-ROM or any portion or copy of it.

**3. Copy Restrictions.** The CD-ROM software and the accompanying materials are copyrighted and contain proprietary information and trade secrets of Lab-Volt. Unauthorized copying of the CD-ROM even if modified, merged, or included with other software or with written materials is expressly forbidden. You may be held legally responsible for any infringement of Lab-Volt's intellectual property rights that is caused or encouraged by your failure to abide by the terms of this agreement. You may make copies of the CD-ROM solely for backup purposes provided the copyright notice is reproduced in its entirety on the backup copy.

**4. Permitted Uses.** This CD-ROM, Instructor's Guide, and all accompanying documentation is licensed to you, the Licensee, and may not be transferred to any third party for any length of time without the prior written consent of Lab-Volt. You may not modify, adapt, translate, reverse engineer, decompile, disassemble, or create derivative works based on the Lab-Volt product without the prior written permission of Lab-Volt. Written materials provided to you may not be modified, adapted, translated, or used to create derivative works without the prior written consent of Lab-Volt.

**5. Termination.** This agreement is effective until terminated. It will terminate automatically without notice from Lab-Volt if you fail to comply with any provisions contained herein. Upon termination you shall destroy the written materials, Lab-Volt's CD-ROM software, and all copies of them, in part or in whole, including modified copies, if any.

**6. Registration.** Lab-Volt may from time to time update the CD-ROM. Updates can be made available to you only if a properly signed registration card is filed with Lab-Volt or an authorized registration card recipient.

**7. Miscellaneous.** This agreement is governed by the laws of the State of New Jersey.

## Limited Warranty and Disclaimer

This CD-ROM software has been designed to assure correct operation when used in the manner and within the limits described in this Instructor's Guide. As a highly advanced software product, it is quite complex; thus, it is possible that if it is used in hardware configurations with characteristics other than those specified in this Instructor's Guide or in environments with non-specified, unusual, or extensive other software products, problems may be encountered by a user. In such cases, Lab-Volt will make reasonable efforts to assist the user to properly operate the CD-ROM but without guaranteeing its proper performance in any hardware or software environment other than as described in this Instructor's Guide.

This CD-ROM software is warranted to conform to the descriptions of its functions and performance as outlined in this Instructor's Guide. Upon proper notification and within a period of one year from the date of installation and/or customer acceptance, Lab-Volt, at its sole and exclusive option, will remedy any nonconformity or replace any defective compact disc free of charge. Any substantial revisions of this product, made for purposes of correcting software deficiencies within the warranty period, will be made available, also on a licensed basis, to registered owners free of charge. Warranty support for this product is limited, in all cases, to software errors. Errors caused by hardware malfunctions or the use of nonspecified hardware or other software are not covered.

LICENSOR MAKES NO OTHER WARRANTIES OF ANY KIND CONCERNING THIS PRODUCT, INCLUDING WARRANTIES OR MERCHANTABILITY OR OF FITNESS FOR A PARTICULAR PURPOSE. LICENSOR DISCLAIMS ALL OBLIGATIONS AND LIABILITIES ON THE PART OF LICENSOR FOR DAMAGES, INCLUDING BUT NOT LIMITED TO SPECIAL OR CONSEQUENTIAL DAMAGES ARISING OUT OF OR IN CONNECTION WITH THE USE OF THE SOFTWARE PRODUCT LICENSED UNDER THIS AGREEMENT.

Questions concerning this agreement and warranty and all requests for product repairs should be directed to the Lab-Volt field representative in your area.

**LAB-VOLT SYSTEMS, INC.**

**P.O. Box 686**

**Farmingdale, NJ 07727**

**Attention: Program Development**

**Phone: (732) 938-2000 or (800) LAB-VOLT**

**Fax: (732) 774-8573**

**Technical Support: (800) 522-4436**

**Technical Support E-Mail: [techsupport@labvolt.com](mailto:techsupport@labvolt.com)**



# Table of Contents

<b>Unit 1 – Introduction to Fiber Optics .....</b>	<b>1</b>
Exercise 1 – Familiarization.....	5
Exercise 2 – Fiber Optic Communications .....	8
<b>Unit 2 – Fiber-Optic Cable &amp; Optical Fiber .....</b>	<b>11</b>
Exercise 1 – Scattering and Absorption Losses .....	19
Exercise 2 – Connectors & Polishing.....	21
Exercise 3 – Numerical Aperture & Core Area .....	23
Exercise 4 – Bending Loss & Modal Dispersion.....	25
<b>Unit 3 – Fiber Optic Transmitter .....</b>	<b>27</b>
Exercise 1 – Light Source .....	31
Exercise 2 – Driver Circuit .....	33
Exercise 3 – Source-to-Fiber Connection .....	35
<b>Unit 4 – The Fiber Optic Receiver.....</b>	<b>39</b>
Exercise 1 – Light Detectors .....	43
Exercise 2 – Receiver Output Circuits .....	45
<b>Unit 5 – Fiber-Optic Systems.....</b>	<b>47</b>
Exercise 1 – Optical Power Budget .....	50
Exercise 2 – Fiber-Optic Equipment.....	52
<b>Unit 8 – Microprocessor Interface.....</b>	<b>55</b>
Exercise 1 – Serial Interface .....	57
<b>Appendix A – Safety .....</b>	<b>A-1</b>

## Introduction

This Student Workbook provides a unit-by-unit outline of the Fault Assisted Circuits for Electronics Training (F.A.C.E.T.) curriculum.

The following information is included together with space to take notes as you move through the curriculum.

- ◆ The unit objective
- ◆ Unit fundamentals
- ◆ A list of new terms and words for the unit
- ◆ Equipment required for the unit
- ◆ The exercise objectives
- ◆ Exercise discussion
- ◆ Exercise notes

The **Appendix** includes safety information.



## UNIT 1 – INTRODUCTION TO FIBER OPTICS

### UNIT OBJECTIVE

At the completion of this unit, you will be able to identify the different circuit blocks on the FIBER OPTIC COMMUNICATIONS circuit board. You will also be able to describe the basic parts of a fiber-optic communication link.

### UNIT FUNDAMENTALS

People have used light to communicate for many years. Our prehistoric ancestors used small fires to signal each other. Lighthouses have been used to warn sailors for thousands of years. Sailors also used flashes of light to transmit and receive messages with Morse code.

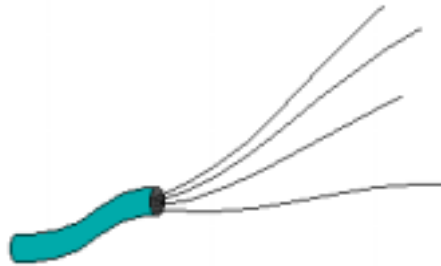

Today, telecommunication companies use light and **fiber optics** to carry audio, video, and data signals over wide areas around the world. Fiber optics is a field of technology that uses thin, flexible, transparent fibers to carry light. Fiber optics combines the use of light, optics, and electronics to transfer information.



The transparent fibers, called **optical fibers**, are made of glass or plastic. Light enters one end of the fiber, travels the length of the fiber, and exits the opposite end.

The light that is passed through an optical fiber, sometimes called a light pipe, has many uses. It is used for transmitting digital, audio, and video signals. It is also used for projecting images, remote sensing, and indicating. Fiber-optic cables, which can consist of several optical fibers, have many advantages over using copper-wire cables.

Several advantages of fiber optics are:

- **Wide bandwidth** - Optical fiber can handle signals up to 1 THz (terahertz), which allows high speed data transfers up to 10 Gbps (625,000 pages of text per second, or 65,000 simultaneous telephone conversations over one fiber).
- **Low loss** - The small signal loss in optical fiber allows the use of fewer repeaters.
- **EMI immunity** - Optical fiber is unaffected by electromagnetic fields, such as RFI (radio frequency interference), and does not create electromagnetic interference.
- **Light weight** - Optical fiber is up to nine times lighter and, therefore, is invaluable to the aircraft industry.
- **Small size** - Optical fiber allows space savings in aircraft and submarines.
- **Safety** - Optical fiber does not create electrical fire hazards and does not attract lightning.
- **Security** - Optical fiber does not radiate energy, so illegal eavesdropping is extremely difficult.
- **Ruggedness** - Glass fiber is corrosion resistant and is 20 times stronger than steel.

When handling fiber-optic cables, you should keep several personal safety precautions in mind:

- **Never** look directly into the end of an optical fiber.

The light source could be a laser, or laser LED, which can actually burn living tissue inside your eyes and permanently blind you. Often, you cannot be certain that the light source is not a laser type or that the light source is turned off.

- **Never** deliberately break a glass optical fiber without properly protecting your eyes and skin.

Glass splinters that are smaller in diameter than a human hair can puncture your skin and become embedded.

In this exercise, you will become familiar with the twelve circuit blocks on your circuit board. You will examine and demonstrate typical fiber-optic circuits and how they are applied in practical situations.

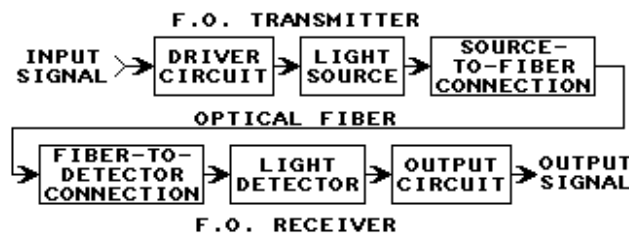

In the second exercise, you will learn the basic parts of a fiber-optic communication link. You will demonstrate the operation of an **analog** and a **digital** fiber-optic communication link.

## NEW TERMS AND WORDS

***fiber optics*** - the technique of conveying light through optical fibers.

***optical fibers*** - (or optical waveguides, or light pipes) thin glass or plastic flexible rods through which light can propagate. These consist of an inner core and an outer cladding, and are found inside fiber-optic cables.

***data link*** - a communication link that allows the transfer of digital data.

***handshaking*** - a method of data-flow control between two stations during the exchange of information.

***Manchester*** - a method of biphasic line coding where data bits are combined with the bit clock through an exclusive-OR (XOR) function. Manchester encoding produces a signal transition during each bit time.

***FPGA*** - a high-density integrated-circuit (IC) that can be user-configured to create a custom IC with user-defined logic functions.

***infrared*** - a form of radiant energy with wavelengths between 770 nm and 1 mm, which is just below the visible light region of the electromagnetic spectrum; a type of invisible light.

***ILED*** - an LED type of output transducer that emits infrared light instead of visible light when forward biased.

***multimode fibers*** - types of optical fibers that provide many propagation paths for light. They are used with an LED light source.

***simplex cables*** - a type of fiber-optic cable that contains only one optical fiber.

***phototransistor*** - a light-sensitive transistor whose collector current is directly related to light intensity.

***photodiode*** - a light-sensitive diode whose conduction is directly related to light intensity.

## EQUIPMENT REQUIRED

F.A.C.E.T. base unit

FIBER OPTIC COMMUNICATIONS circuit board

Multimeter

Oscilloscope, dual trace

Signal Generator, sine wave



## Exercise 1 – Familiarization

### EXERCISE OBJECTIVE

When you have completed this exercise, you will be able to describe and locate the different circuit blocks on the FIBER OPTIC COMMUNICATIONS circuit board.

### DISCUSSION

- The twelve circuit blocks on the FIBER OPTIC COMMUNICATIONS circuit board allow you to experiment with several fiber-optic trans-mission and reception methods.
- Twelve faults have been incorporated into the circuitry to challenge your troubleshooting skills in Unit 7 - TROUBLESHOOTING.
- The POWER SUPPLY circuit block provides regulated and filtered +5V and -5V dc to all circuits on the board.
- The circuit board can be powered by the F.A.C.E.T. Base Unit or by an ac adapter that can be plugged into the POWER jack.
- An LED lamp indicates when power is applied to the board.
- The POWER switch is not functional while your board is installed in a F.A.C.E.T. Base Unit. It is only used for stand-alone operation of your circuit board.
- The HIGH jack provides a logical HIGH for digital work.
- While using the DIGITAL RECEIVER, DIGITAL TRANSMITTER, or the RS-232 INTERFACE (also digital), the +5V and -5V shunts must be set to their DIGITAL positions.
- While using the ANALOG RECEIVER, ANALOG TRANSMITTER, AUDIO AMPLIFIER, or MIC AMPLIFIER, the +5V and -5V shunts must be set to their ANALOG positions.
- The PHOTO TRANSISTOR and LIGHT EMITTING DIODES circuit blocks are not affected by the power shunts.
- The AUDIO AMPLIFIER circuit block amplifies audio signals that are connected to the AUDIO IN jack.
- The amplified signal is internally connected to the SPEAKER circuit block when the AUDIO OUT shunt is in its SPKR (speaker) position.
- The SPEAKER can be disabled by moving the AUDIO OUT shunt to its NC (no connection) position.
- The SPEAKER circuit block contains a 45Ω speaker that allows you to hear the various audio signals on your board.
- The RS-232 INTERFACE circuit block uses 4-channel TDM (Time-Division Multiplexing) to provide a computer interface and demonstrate a practical use of fiber optics.
- The circuit uses a fiber-optic **data link** to serially receive data from, and transmit data to, a microcomputer or other computer device via its serial port.
- Full **handshaking** is supported, as well as **Manchester** data encoding and decoding techniques.
- Most of these tasks are performed by the circuit block's **FPGA (Field- Programmable Gate Array) IC chip**.

- A thirty-pin test strip, TP1, provides test points for the FPGA's signals. You will use TP1 to help develop an understanding of how the circuit works.
- Nine test points at TP2 are connected to the 9-pin serial port connector so that you can probe the port's pins while a computer is connected to the port.
- The LED lamps to the left of TP2 indicate the status of each signal. A red LED indicates that its corresponding signal is at a HIGH level, and a green LED indicates that its signal is at a LOW level.
- The DIGITAL RECEIVER circuit block receives a signal from the Fiber Optic Receiver.
- The digital receiver converts the signal to digital data at DATA OUT.
- The DIGITAL TRANSMITTER circuit block drives the Fiber Optic Transmitter.
- The digital transmitter converts the digital data at DATA IN to a drive signal for the Fiber Optic Transmitter.
- The ANALOG RECEIVER circuit block receives a signal from the Fiber Optic Receiver.
- The analog receiver converts the signal to an analog signal at R- OUT.
- R-OUT's analog signal can be fed to the AUDIO AMPLIFIER's AUDIO IN, or to a phono connector (VIDEO OUT).
- The GAIN pot must be set for unity gain (a gain of 1) when the analog receiver is used in a complete fiber-optic communication link.
- The ANALOG TRANSMITTER circuit block drives the Fiber Optic Transmitter.
- The analog transmitter converts the analog signal at T-IN to a drive signal for the Fiber Optic Transmitter.
- T-IN's analog signal can come from the MIC AMPLIFIER's MIC OUT, or from a phono connector (VIDEO IN).
- The PHOTO TRANSISTOR circuit block is used to measure relative power levels of light that emanate from the end of an optical fiber.
- The output voltage at the EMITTER test point gives a relative indication of light intensity. For low light levels, such as with glass fibers, the RANGE shunt should be in its LO position. For high light levels, as with plastic fibers, place the RANGE shunt in its HI position.
- The ratio of the two power settings is 100:1.
- The MICROPHONE circuit block contains a 2 k $\Omega$  electret microphone that is internally connected to the MIC AMPLIFIER's input. This allows you to create your own audio signals on the board by talking into the microphone.
- The MIC AMPLIFIER circuit block amplifies the audio signal from the internally connected microphone.
- The amplified audio output signal is available at the MIC OUT jack.
- The audio signal level can be adjusted with the LEVEL control.
- The LIGHT EMITTING DIODES circuit block has three different light sources (red, green, and **IRE**D LEDs). Each LED lamp emits a different wavelength.
- Whenever the board is powered-up, the three LED lamps are on.
- The end of a glass or plastic optical fiber can be placed over top of each LED lamp.
- This circuit block allows you to compare different light sources during your experimentation.
- The optical fibers that are supplied with your board come in two different lengths: 1 meter and 5 meters.
- Besides different lengths, two different types of **multimode fibers** are supplied with your board: 62.5  $\mu\text{m}$  (micrometer) diameter glass and 1000  $\mu\text{m}$  diameter plastic.



## Exercise 2 – Fiber Optic Communications

### EXERCISE OBJECTIVE

When you have completed this exercise, you will be able to describe the basic parts of a fiber-optic communication link. You will demonstrate the operation of an **analog** and a **digital** fiber-optic communication link.

### DISCUSSION

- Fiber optics can be used to send and receive analog information such as audio or video.
- Fiber optics can also be used to transfer digital information such as computer data.
- **Digitized** audio or video signals can be transferred through an optical link as well.
- A fiber-optic communication link consists of several basic parts: a driver circuit, light source, source-to-fiber connection, optical fiber, fiber-to-detector connection, light detector, and output circuit.
- The **driver circuit** usually consists of a transistor to turn the light source on and off at very fast rates. By using a transistor, a high- power light source can be switched on and off.
- This stage receives its input signal from a computer or other peripheral.
- The **light source** is an LED or laser.
- Many different types of LEDs are used for the light source. These include: laser, infrared, and visible types.
- The **source-to-fiber connection** usually consists of a connector on one end of the optical fiber that physically mates with the light source (Fiber Optic Transmitter on your circuit board).
- The **optical fiber** links the light source to the light detector. It consists of two basic parts: a **core**, and a **cladding**.
- A **fiber-optic cable** consists of an optical fiber that is protected by an outer **jacket**.
- Several different layers of material are often used between the optical fiber and the jacket to help protect and strengthen the assembled cable.
- Fiber sizes are commonly expressed by the core diameter followed by the cladding diameter in micrometers ( $\mu\text{m}$ ).
- The glass optical fiber supplied with your board is type 62.5/125, which means it has a core diameter of 62.5  $\mu\text{m}$  and a cladding diameter of 125  $\mu\text{m}$ .
- The **fiber-to-detector connection** consists of a connector on the end of the optical fiber that physically mates with the light detector (Fiber Optic Receiver on your circuit board).
- The **light detector** is typically either a phototransistor or a **photo-diode**, which converts the light energy to electrical energy.
- The output circuit processes, or "cleans up", the signal from the light detector to provide a usable output signal. This stage sends its output signal to a computer or other peripheral.
- A complete **fiber-optic transmitter** consists of a driver circuit, light source, and source-to-fiber connection.
- A complete **fiber-optic receiver** consists of a fiber-to-detector connection, light detector, and output circuit.





## UNIT 2 – FIBER-OPTIC CABLE & OPTICAL FIBER

### UNIT OBJECTIVE

At the completion of this unit, you will be able to describe how light propagates through an optical fiber. You will demonstrate light attenuation due to: numerical aperture, fiber, area, connector, and bending losses.

### UNIT FUNDAMENTALS

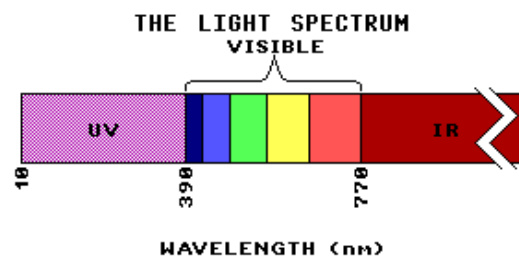

Like a radio wave, light is in the **electromagnetic spectrum**. The wavelength of a light wave is related to its frequency.

$$\lambda = (300,000 \text{ km/s})/f$$

Wavelength ( $\lambda$ ) is the distance an electromagnetic (light) wave travels during one cycle. Light wavelength is calculated by dividing the velocity of light in a vacuum (300,000 km/s) by the light frequency.

In the visible spectrum, light wavelength determines the colors we see. Ultraviolet (UV) wavelengths are below the visible spectrum and are not detectable by the human eye. Infrared (IR) wavelengths are above the visible spectrum which also makes them invisible.

Both visible and invisible electromagnetic waves contain electromagnetic power that can be detected electronically. The entire light spectrum can be used for fiber-optic communications.

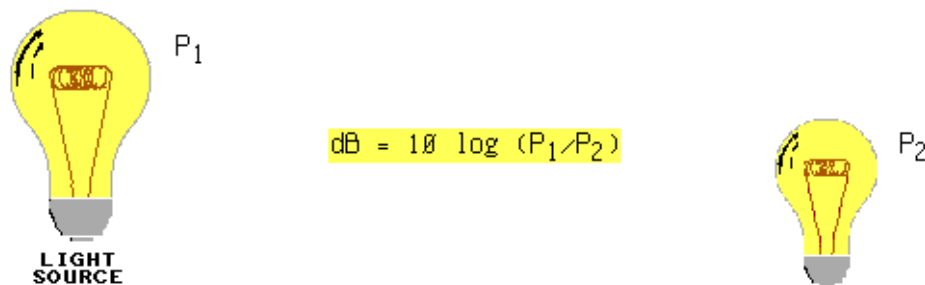

Decibels (dB) are commonly used to express the ratio of two power qualities. The units of  $P_1$  and  $P_2$  cancel, making absolute power measurements unnecessary for dB calculations. If  $P_1$  and  $P_2$  represent relative light power, the correct dB value will result from the calculation.

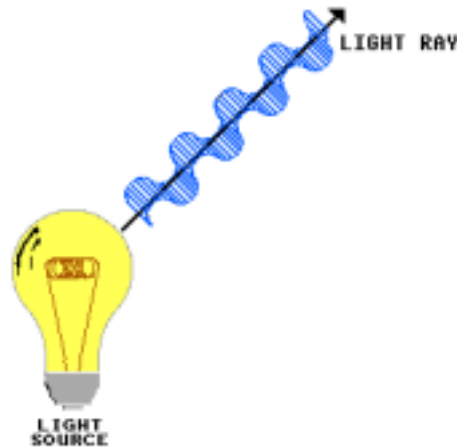

A light wave moves away from its source in a straight path. A light ray is an arrow that represents the path and direction of a wave. A light wave has a flat leading edge called a **wave front**. The light ray (path) is normal (perpendicular, or  $90^\circ$ ) to the wave front.

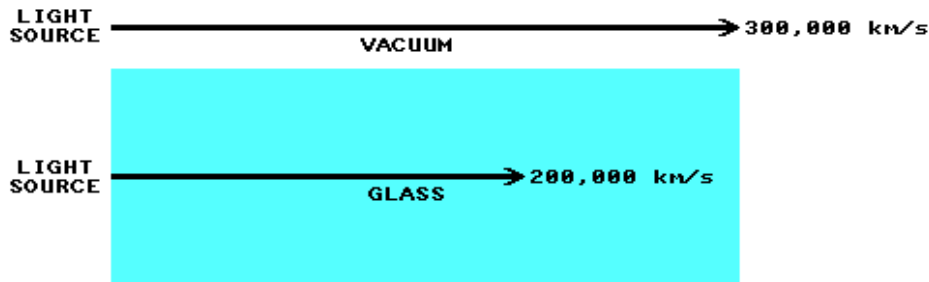

Light traveling in a vacuum has a constant velocity of 300,000 km/s. Light traveling through glass has a velocity of 200,000 km/s.  $\eta = c/v$  Index of refraction ( $\eta$ ) is the ratio between light velocity in a vacuum ( $c = 300,000$  km/s) and light velocity in a material ( $v$ ).

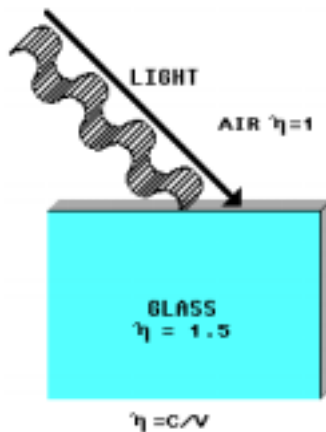

This light wave is propagating through air at about 300,000 km/s. The light velocity will change to 200,000 km/s when the wave front passes into the glass. In this example the light wave encounters the glass at an angle. The light approach-angle can cause part of the wave front to enter glass while the remainder is still in the air.



Light that remains in the air outruns the slower light in the glass. The wave front turns, which changes its direction and bends its path (ray). The bending of light as it moves between materials is called refraction.

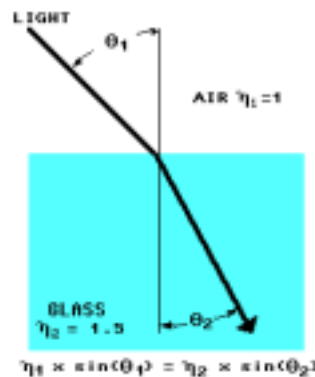

The approach angle of the light ray is called the **angle of incidence** ( $\theta_1$ ). The incident angle of the light is measured between the light ray and a line  $90^\circ$  (normal) to the change in refraction index. The index of refraction of the first (approach) material is  $\eta_1$ .

$\theta_2$  is called the **angle of refraction**. The refraction angle is also measured between the light ray and a line normal ( $90^\circ$ ) to the change in refraction index. The index of refraction of the second material is  $\eta_2$ . Snell's law gives the relationship between the angle of incidence and the angle of refraction.

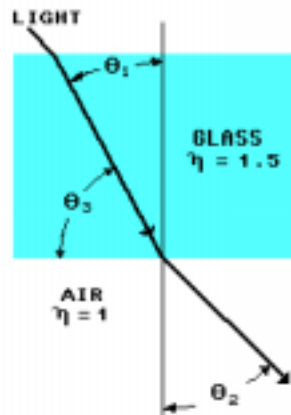

The light ray is also refracted when it moves from the glass to the air.

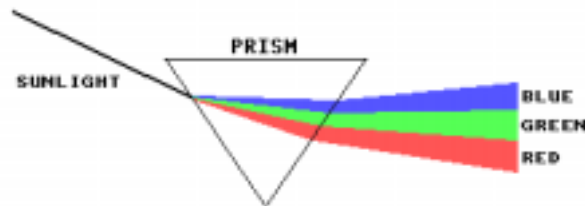

Light velocity in a material is affected by wavelength. Because refraction index is dependent on light velocity ( $\eta = c/v$ ), a material's index changes with light wavelength.

A prism separates light by color because each wavelength has a slightly different velocity and, therefore, its own refraction index and angle of refraction.

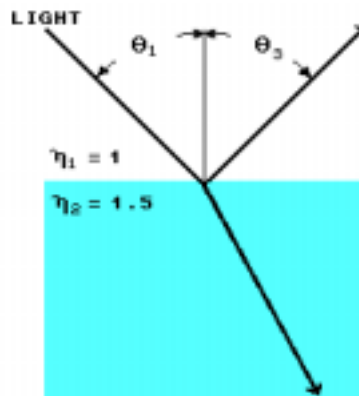

Whenever light travels through a change in index ( $\eta_1$  to  $\eta_2$ ) a **portion** of the light is always reflected back into the first material. These reflections are called **Fresnel reflections**. The angle of reflection  $\theta_3$  always equals the incident angle  $\theta_1$ .

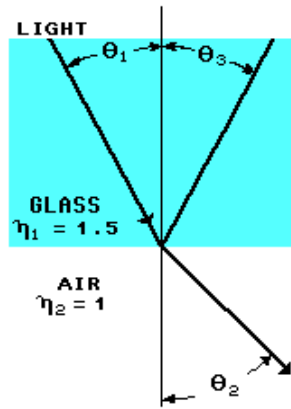

Consider a light ray that is refracted by a decrease in refraction index ( $\eta_2 < \eta_1$ ). The incident angle ( $\theta_1$ ) is  $28^\circ$ . Using Snell's law the angle of refraction ( $\theta_2$ ) is  $45^\circ$ .

The **decrease** in refraction index bent the light ray **away** from the normal line.

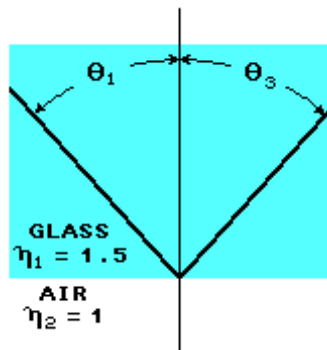

Increasing the incident angle ( $\theta_1$ ) to  $42^\circ$  causes all of the light to be reflected and remain in the glass. Total reflection occurs when the incident angle ( $\theta_1$ ) is **greater than** the **critical angle**.

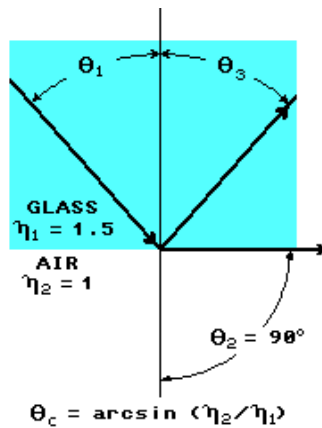

The critical angle ( $\theta_c$ ) equals the incident angle ( $\theta_1$ ) which causes a  $90^\circ$  angle of refraction ( $\theta_2$ ).

$\theta_c$  is calculated by using Snell's law and setting  $\theta_2$  equal to  $90^\circ$ .  $n_1 \times \sin(\theta_c) = n_2 \times \sin(90^\circ)$

The sine of  $90^\circ$  equals 1, which simplifies the critical angle formula to:  $\theta_c = \arcsin(n_2/n_1)$ .

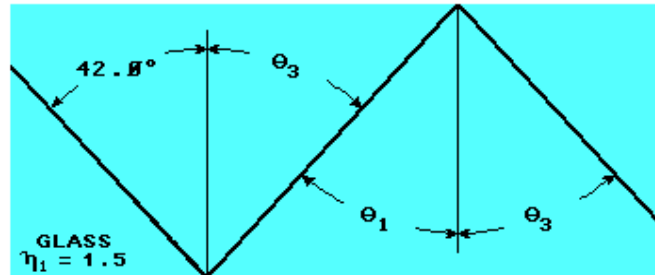

Consider a ray that has an incident angle greater than the critical angle ( $42^\circ > 41.8^\circ$ ) at the glass to air boundary. The light is totally reflected at an angle ( $\theta_3$ ) which equals the incident angle of  $42^\circ$ .

The glass top and bottom surfaces are parallel, forming a rectangle between the glass boundaries and the normal lines. The light ray travels along the diagonal, causing the next incident angle to equal the previous angle of reflection. The reflections repeat as the light ray propagates within the glass.

The glass is acting as a **waveguide**, steering the light using total reflection at the glass to air boundaries.

## NEW TERMS AND WORDS

**electromagnetic spectrum** - the range of electromagnetic wavelengths where radiant energy oscillates between electric and magnetic fields.

**wave front** - a set of points that are in phase and perpendicular to the direction of wave travel.

**angle of incidence** - the approach angle of a light ray. The angle between a light ray in the first material to a line normal to the change in refraction index.

**angle of refraction** - the angle between a light ray in the second material to a line normal to the change in refraction index.

**Fresnel reflections** - a portion of light that is always reflected off a change in refraction index.

**critical angle** - the largest angle of incidence which permits the refraction of light.

**waveguide** - boundaries that direct electromagnetic energy.

**cladding** - a coating surrounding the optical-fiber core that has a lower refractive index.

**absorption** - power loss from the conversion of light energy to heat.

**scattering** - misdirecting or spreading of light power.

**microbends** - small bends in the core to cladding surface caused by the fiber manufacturing process.

**concentric** - having the same center.

**lapping films** - abrasive films used for fine polishing (lapping).

***lateral displacement*** - moved to one side. Distance off center.

***pistoning*** - the movement of an optical fiber within a ferrule or connector.

***acceptance angle*** - the angle between light and the fiber axis at which the fiber power output is reduced by half. Sometimes confused with acceptance cone.

***acceptance cone*** - a three dimensional representation of light acceptance defined by rotating the fiber acceptance angle around the fiber axis.

***numerical aperture (NA)*** - a number that represents an optical fiber's acceptance angle.

***unintercepted illumination*** - light that does not fall on the fiber's core.

***modes*** - paths taken by light. An electromagnetic field distribution.

***dispersion*** - the spreading of energy in time.

***modal dispersion*** - the spreading of power in time caused by differing mode path lengths.

***multimode fiber*** - an optical fiber that allows many light modes to propagate.

***chromatic dispersion*** - the spreading of energy in time caused by differing light wavelengths (color).

## **EQUIPMENT REQUIRED**

In order to complete the following exercises, you will need:

F.A.C.E.T. base unit

FIBER OPTIC COMMUNICATIONS circuit board with the FIBER OPTIC POLISHING KIT

Multimeter

Oscilloscope, dual trace

Generator, sine wave



## Exercise 1 – Scattering and Absorption Losses

### EXERCISE OBJECTIVE

At the completion of this exercise you will understand the attenuation that occurs when light travels through a fiber-optic cable. You will calculate and measure the power loss through an optical fiber.

### DISCUSSION

- All fiber-optic cables have two main parts: the optical fiber and the jacket.
- The optical fiber consists of a core surrounded by a **cladding**.
- Together the core and cladding form a **waveguide** that steers light through the fiber.
- The jacket protects the fiber and provides mechanical support.
- Glass fibers are usually protected by additional strength and buffer layers that protect the glass fiber from shock and sharp bends.
- The diameter of a glass fiber is small enough to easily pass through your skin and cause a serious injury.
- The fiber-optic cable assemblies provided with your circuit board are intended to prevent exposure to the glass fiber; do not attempt to modify the cable or connectors.
- To prevent accidents, dispose of damaged glass fiber cables immediately.
- The glass fiber-optic cables are marked with the numbers 62.5/125, designating the core and cladding diameters.
- The plastic cable provided with the circuit board has step index optical fiber.
- The refractive index of the fiber changes abruptly at the core and cladding interface.
- The refractive index of the cladding is 1.417; the **core** refractive index is 5% higher or 1.492.
- Light traveling through the fiber core reflects off the cladding because of the step change in the refraction index.
- The 62.5/125 glass cable provided with the circuit board has a graded index fiber.
- The refraction index of the core changes gradually as the light moves away from the center of the core.
- As light travels toward the cladding, the gradual lowering of the refraction index bends (refracts) the light, increasing the angle of incidence.
- When the angle of incidence becomes large enough, the light reflects back towards the center.
- Optical fibers are not ideal waveguides; some of the input light power is lost to **absorption** and **scattering**.
- Impurities in the fiber material will absorb some of the optical power and dissipate it as heat.
- Absorption losses are affected by core material and light wavelength.
- Manufacturing variations in the density or composition of the fiber scatter some of the light.
- Imperfections in the core to cladding interface are called **microbends**.
- Microbends cause additional scattering losses, which decrease as wavelength increases.
- Fiber manufacturers specify the combined scattering and absorption losses in decibels per kilometer (dB/km).



## Exercise 2 – Connectors & Polishing

### EXERCISE OBJECTIVE

At the completion of this exercise, you will be able to cut and polish plastic fiber-optic cable. You will also be able to identify losses in optical connections using visual inspection and power measurements.

### DISCUSSION

- Consider two parallel light rays propagating out of one optical fiber and into another.
- If the fibers are misaligned, one ray passes into the second fiber and continues; the other ray is lost when it misses the second fiber.
- Fiber-optic connectors reduce attenuation by holding their optical fibers in alignment.
- The main parts of a fiber-optic connection are ferrule, coupling nut, coupling receptacle, and strain relief
- The ferrule and coupling receptacle provide fiber alignment while the remainder of the connector provides mechanical support.
- The ferrule is a cylinder that holds the optical fiber.
- The fiber passes through a hole in the ferrule center allowing only the fiber end to be exposed.
- The fiber is secured to the ferrule using an adhesive or crimping action.
- A coupling receptacle (mating sleeve) precisely aligns the ferrules.
- The fibers are **concentric** within the ferrules causing the fiber ends to align when the ferrules are aligned.
- Ferrules and coupling receptacles are manufactured from plastic, metal, or ceramic.
- Ceramic connectors can be manufactured to tighter tolerances than plastic, providing better fiber alignment and reduced attenuation.
- Metal (stainless steel) performs better than plastic but not as well as ceramic.
- Connector attenuation is specified by the manufacture in dB. A typical optical connection has about 0.5 dB of loss.
- Light entering a fiber end must pass through the increase in refraction index that occurs at the air-to-core interface.
- A light ray passing from the lower index (air) to the higher refraction index of the core is bent (refracted) towards a line normal to the interface between the two materials.
- The relationship between the angle of incidence and the angle of refraction is described by Snell's law.
- An uneven fiber surface scatters light which increases attenuation.
- To reduce scattering the fiber ends are polished using special **lapping films**, which are capable of producing a surface that is smooth to within 0.05  $\mu\text{m}$ .



## Exercise 3 – Numerical Aperture & Core Area

### EXERCISE OBJECTIVE

When you have completed this exercise you will be able to explain how numerical aperture (NA) affects attenuation and how attenuation is affected by fiber core area. You will calculate attenuation due to numerical aperture and core area mismatches and verify your results using relative power measurements.

### DISCUSSION

- Snell's law describes how light behaves when it travels between two materials with different refraction indices.
- Snell's law can also predict if the light will be refracted or totally reflected.
- Total light reflection occurs when the incident angle ( $\theta_1$ ) is greater than the critical angle.
- The critical angle is calculated by setting  $\theta_2$  to  $90^\circ$  and solving for  $\theta_1$ .
- Because  $\sin(90^\circ)$  is equal to 1, the critical angle is equal to  $\arcsin(n_2/n_1)$ .
- The critical angle ( $\theta_c$ ) is the largest incident angle ( $\theta_1$ ) that will be refracted by the decrease in refractive index.
- Light rays with an angle of incidence ( $\theta_1$ ) **greater than** the critical angle ( $\theta_c$ ) are totally reflected.
- **Acceptance cone** is a three-dimensional representation of light acceptance which measures twice the acceptance angle.
- A useful expression of a fiber's acceptance angle is its **numerical aperture** (NA).
- NA is calculated by taking the sine of the acceptance angle ( $\theta_A$ ).



## Exercise 4 – Bending Loss & Modal Dispersion

### EXERCISE OBJECTIVE

When you have completed this exercise you will be able to explain why fiber bending increases attenuation, how propagation **modes** affect dispersion, and why **dispersion** limits fiber bandwidth. You will calculate the bandwidth for a length of fiber and verify bending losses using relative power measurements.

### DISCUSSION

- A typical plastic fiber has many modes (paths) of light propagation.
- The most direct modes take a short path straight through the fiber and arrive first.
- Some modes follow a longer path and arrive later.
- The ratio of the longest to shortest path length equals the sine of the fiber's critical angle.
- The velocity of light in a vacuum ( $c$ ) is a constant 300,000 km/s.
- The core refractive index ( $\eta$ ) is the ratio between  $c$  and the velocity of 635 nm light in the fiber core ( $\eta = c/v$ ).
- The spreading of energy caused by the fiber's differing mode path lengths is called **modal dispersion**.
- Modal dispersion causes phase shifts which reduce the fiber's bandwidth and flatten out the received pulse.
- For **multimode fiber** the dispersion is specified as the maximum bandwidth of a one kilometer fiber.
- Plastic fiber has a kilometer bandwidth of 5 MHz.
- The fiber with the smaller acceptance angle (or NA) has a larger critical angle.
- The ratio of the longest to shortest path length is equal to the sine of the fiber's critical angle.
- Reducing the fiber acceptance angle makes the mode path lengths closer, reducing modal dispersion.
- The fiber with the lower acceptance angle also supports fewer propagation modes.
- The number of modes can also be reduced by reducing the core diameter.
- The glass multimode graded index 62.5/125 fiber has approximately 1800 modes.
- Fewer propagation modes generally cause less modal dispersion, giving the glass multimode fiber a kilometer bandwidth of 200 MHz.
- Increasing the kilometer bandwidth allows higher transmission rates over longer distances.
- Single-mode fibers use a small core diameter (3 - 10  $\mu\text{m}$ ) and a low NA (0.12 - 0.18) to insure a single propagation path.
- Single-mode fiber is the best choice for high bandwidth and long distances.
- Single-mode fiber requires a highly directional light source (laser) and special single-mode connectors.



## UNIT 3 – FIBER OPTIC TRANSMITTER

### UNIT OBJECTIVE

At the completion of this unit, you will be able to identify, describe, and demonstrate the parts of a fiber-optic transmitter.

### UNIT FUNDAMENTALS

Light is made up of electromagnetic waves or of particles called **photons**. A photon is a bundle of energy, and is peculiar in that, if it does not move, it does not exist.

In the previous unit, you were introduced to the wavelength and frequency of electromagnetic radiation. The amount of energy (E) in a photon increases with frequency (f), and can be calculated using Planck's constant ( $\eta$ ).

$$E = \eta \times f$$

$$E \text{ (watts)} = 6.63 \times 10^{-34} \text{ (joule-seconds)} \times f \text{ (hertz)}$$

$$E = \eta \times f$$

$$E \text{ (W)} = 6.63 \times 10^{-34} \text{ js} \times f \text{ (Hz)}$$

A photon of red light having a wavelength of 650 nm, a frequency of 461.5 THz (terahertz = Hz  $\times 10^{12}$ ), contains about  $3 \times 10^{-19}$  watts (0.0000003 pW) of energy.

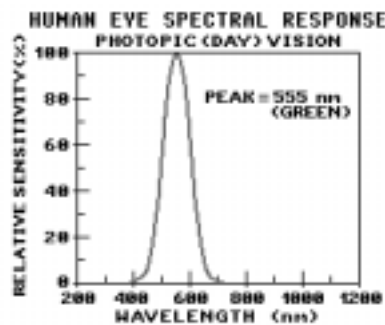

Light power is defined several different ways for different circumstances.

Optical power, which includes all light types, is specified using.

For **visible light**, **photometric** parameters can be used to indicate the visibility of light in the range of wavelengths that we can see.

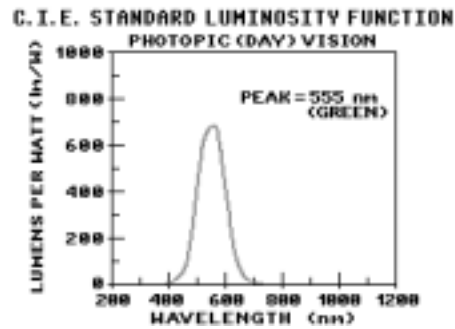

**Photometric** quantities can be related to corresponding **radiometric** quantities by using the C.I.E. Standard Luminosity Function.



This function is essentially a filter that emulates the behavior of an average human eye in daylight. You can refer to this function as the "standard eye". Five **radiometric** parameters are commonly used to specify power from a light source (emitter):

**Radiant Energy** - The total energy emitted from a source.

**Radiant Power (Flux)** - The total power (time rate of energy flow) emitted from a source.

**Radiant Intensity** - (Power intensity) The power emitted from a source per unit solid angle.

**Radiant Emittance (Exitance)** - (Power density) The power emitted from a source per unit surface area.

**Radiance** - The intensity emitted from a source per unit surface area.

Five **photometric** parameters are commonly used to specify power from a **visible** light source or emitter:

**Luminous Energy** - The total energy emitted from a visible source.

**Luminous Power (Flux)** - The total power (time rate of energy flow) emitted from a visible source.

**Luminous Intensity** - (Light intensity) The power emitted from a visible source per unit solid angle.

**Luminous Emittance (Exitance)** - (Light density) The power emitted from a visible source per unit surface area.

**Luminance** - The intensity emitted from a visible source per unit surface area.

Radiometric and photometric parameters are specified with many different units of measure. Some of these units, lumens for example, are used strictly for photometric, not radiometric, purposes.

By clicking Resources and selecting Fiber Optic Communications Help, then selecting Radiometric Parameters or Photometric Parameters, you can see some of the more commonly used units of measure for radiometric and photometric parameters.



In the first exercise, you will become familiar with characteristics of fiber-optic transmitter light sources.

In the second exercise, you will learn about several types of driver circuits that are commonly used in analog and digital fiber-optic transmitter circuits.

In the third exercise, you will discover characteristics that cause light attenuation in fiber-optic transmitter source-to-fiber connections.

As in the previous unit, you will use PHOTO TRANSISTOR circuit block EMITTER voltage to measure relative light power.

## NEW TERMS AND WORDS

**photometric** - a system or parameter used to specify visible properties of electromagnetic radiation.

**radiometric** - a system or parameter used to specify physical properties of electromagnetic radiation.

**C.I.E.** - (Commission Internationale de l' Eclairage). A French organization of illumination standards.

**point source** - a light source whose diameter is at least ten times smaller than the distance between the source and detector.

**photons** - elementary quantities of radiant energy, which can be considered to be particles of light.

**radiation** - the emission of electromagnetic energy.

**chromatic dispersion** - the spreading of energy in time caused by differing light wavelengths (color).

**radiation efficiency** - the ratio input power of radiant power to a light source.

**steradian** - a unit of measure for a solid angle.

**luminous efficacy** - an efficiency rating of a visible light source equal to the ratio of luminous power to radiant power in lumens per watt (lm/W).

**quiescent** - a stable, inactive operating point or condition.

## EQUIPMENT REQUIRED

F.A.C.E.T. base unit

FIBER OPTIC COMMUNICATIONS circuit board

Multimeter

Oscilloscope, dual-trace

Signal Generator, sine/square wave



## Exercise 1 – Light Source

### EXERCISE OBJECTIVE

When you have completed this exercise, you will be able to describe light sources used in fiber-optic systems that convert an electrical signal into an optical signal.

### DISCUSSION

- Electromagnetic energy travels outward from a source at constant velocity. This "traveling" process is known as radiation.
- A light source in a fiber optic transmitter converts electrical energy to radiant electromagnetic energy that is either visible or invisible.
- The light source in a fiber-optic transmitter consists of an LED or laser.
- White light is divergent; it spreads out with distance. **Laser** light is **collimated**; it stays confined with distance.
- White light is chromatic; it contains many colors of light. **Laser** light is **monochromatic**; it is only one color.
- **Laser** light is **coherent**; its waves are in unison.
- An LED emits light when its PN junction is forward biased.
- When the distance between an object and its light source is at least ten times greater than the size of the light source, the light source is considered to be a **point source** of light.
- The inverse-square law states that the power density of light ( $E_e$ ) from a point source decreases proportionally as the square of the distance ( $d$ ).
- Light source spectral width, or purity, affects **chromatic dispersion** within the optical fiber.
- Light emitting diode spectral bandwidth is specified by its full-width half-maximum (FWHM) rating *or* by half this value, called spectral halfwidth.
- Light source output-power affects the maximum length of the fiber-optic system. More light power allows longer optical fibers to be used in the system.
- Light-source speed affects the bandwidth of a fiber-optic system. The greater the bandwidth requirement, the greater the need to turn the light source on and off more quickly.
- Light-source speed is defined in terms of rise time ( $t_r$ ):  $BW_{\max} = 0.35/t_r$
- Beam **angle** and beam **width** must be known to help determine how much radiant power actually enters into and travels through the optical fiber.
- Numerical aperture mismatch, when the beam is wider than the acceptance angle of the fiber, results in a loss of power called numerical aperture loss.
- Area mismatch, when light may not enter the fiber because the beam **width** is wider than the fiber's core, is a loss of power called unintercepted illumination loss (**IU loss**).



## Exercise 2 – Driver Circuit

### EXERCISE OBJECTIVE

When you have completed this exercise, you will be able to describe the circuits used to interface an analog and a digital signal to a fiber-optic light source.

### DISCUSSION

- A fiber-optic transmitter requires electronic circuitry, called the driver circuit, to control the electrical input to its light source.
- Power and switching speed are important characteristics of a fiber-optic-transmitter driver circuit.
- A driver circuit, without overheating, must apply electrical power to a light source so that enough optical power is produced for the system.
- Two basic types of driver circuits, series and shunt, are used in FOT's.
- The most common driver circuits use a transistor to control LED current.
- A series driver circuit has its transistor connected in series with the LED.
- A shunt driver circuit has its transistor connected in parallel with the LED.
- A technique known as pre-biasing or "priming" the LED allows LED and transistor junction capacitance to charge before the LED is switched on.
- RC current-peaking circuitry improves driver-circuit bandwidth.
- The ANALOG TRANSMITTER circuit board uses a buffer amplifier in its driver circuit as a voltage-to-current converter. An ac input voltage creates an ac current that modulates the optical output of an LED.



## Exercise 3 – Source-to-Fiber Connection

### EXERCISE OBJECTIVE

When you have completed this exercise, you will be able to describe the factors that introduce losses in a fiber-optic transmitter's source-to-fiber connection.

### DISCUSSION

- The source-to-fiber connection in a fiber-optic transmitter is an optical and mechanical interface between the light source (an LED or laser) and one end of the optical fiber.
- Light attenuation at the source-to-fiber connection is known as coupling loss.
- Misalignment, area mismatch, numerical aperture mismatch, Fresnel reflection, and poor surface finish result in coupling losses between the light source and optical fiber.
- The light source and optical fiber must be properly aligned to minimize losses.
- Lateral displacement causes some light to miss the end of the fiber.
- Angular misalignment causes some light to exceed the fiber acceptance angle.
- The circuit board uses standard ST-style fiber-optic connectors, which minimize alignment losses.
- An area mismatch can cause a loss of power called Unintercepted Illumination loss ( $LOSS_{UI}$ ).
- If the diameter of the light at the fiber end ( $D_1$ ) is greater than the fiber's core diameter ( $D_2$ ), not all the light is coupled into the end of the optical fiber.
- The loss due to area mismatch can be determined by the ratio of the two diameters:  $LOSS_{UI}$  (in dB) =  $20 \times \log (D_1/D_2)$
- If the diameter of light entering the fiber is less than or equal to the fiber's core diameter, all light from the source is coupled into the end of the optical fiber, and no loss occurs due to area mismatch.
- $LOSS_{UI}$  (in dB) =  $20 \times \log (D_1/D_2)$ . Increasing **distance** between the light source and optical fiber can increase the diameter of light at the end of the fiber.
- As separation distance is **decreased**, the UI loss decreases.
- A **Numerical Aperture** mismatch can cause a loss of power, called an **NA loss**.
- If the NA of the light source ( $NA_1$ ) is greater than the fiber's NA ( $NA_2$ ), not all the light is coupled into the end of the optical fiber.
- The NA of a light source can be determined by using the beam angle of the source ( $\theta_B$ ):  $NA_1 = \sin \theta_B$ . The NA of an optical fiber can be determined by using its acceptance angle ( $\theta_A$ ):  $NA_2 = \sin \theta_A$ .
- The loss due to NA mismatch can be determined by the ratio of the two NA values:  $LOSS_{NA}$  (in dB) =  $20 \times \log (NA_1/NA_2)$ .
- If the NA of a light source is less than or equal to the fiber NA, all light is coupled into the end of the optical fiber, and no loss occurs due to NA mismatch.
- Fiber supplied with the circuit board has an acceptance angle ( $\theta_A$ ) of  $16^\circ$ .
- The NA of the **glass** optical fiber ( $NA_2$ ) is 0.275.

- A Fresnel reflection is a partial reflection of light caused by a change in refractive index along the light path.
- A Fresnel reflection causes a loss of power, called reflection loss ( $LOSS_R$ ).
- The reflectivity ( $r$ ) caused by the change in refractive index from the first material ( $h_1$ ) to a second material ( $h_2$ ) can be determined by:  
$$r = [(h_2 - h_1) / (h_2 + h_1)]$$
- Power loss due to Fresnel reflection can be determined by:  
 $LOSS_R \text{ (in dB)} = 10 \times \log(1 - r)$ .
- Surfaces of a light-source lens and optical-fiber end must be kept clean and smooth to minimize power losses.
- Dust and dirt on surfaces can partially block a light path.
- Surface defects such as scratches or grooves can alter the direction of the light path.
- The polish at each ST-connector typically causes an additional 0.25 dB of light attenuation for a total finish loss of about 0.5 dB per fiber- optic cable.
- To find total power loss at the source-to-fiber connection, you simply add the losses:  
 $Coupling \text{ losses} = LOSS_{UI} + LOSS_{NA} + LOSS_R + LOSS_F$
- The 1-meter **glass** fiber-optic cable attenuates light by less than 0.003 dB. For all practical purposes, this small power loss can be ignored in this procedure.





## UNIT 4 – THE FIBER OPTIC RECEIVER

### UNIT OBJECTIVE

At the completion of this unit you will be able to identify, describe, and demonstrate the parts of a fiber-optic receiver.

### UNIT FUNDAMENTALS

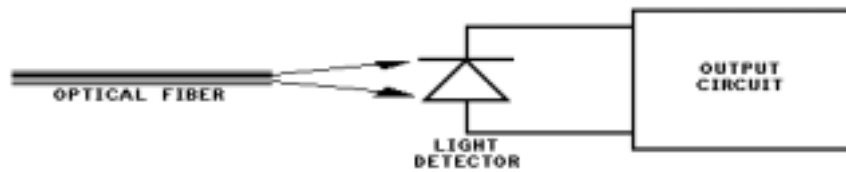

A fiber-optic receiver consists of a light detector, fiber-to-detector connection, and an output circuit. The fiber-to-detector connection allows light from the fiber to illuminate the light detector.

The light detector converts an optical signal delivered by the optical fiber to an electric current signal. The output circuit converts the light detector signal into a format compatible with other system components.

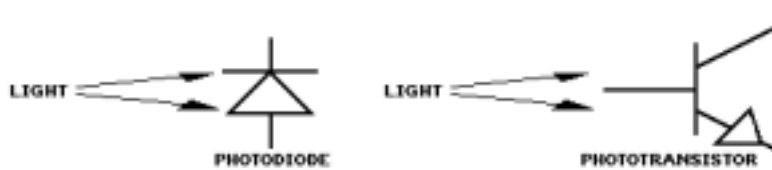

In a fiber-optic system, the light detector is usually a photodiode or phototransistor. Both of these devices use radiant power (light) to control their current (photocurrent).

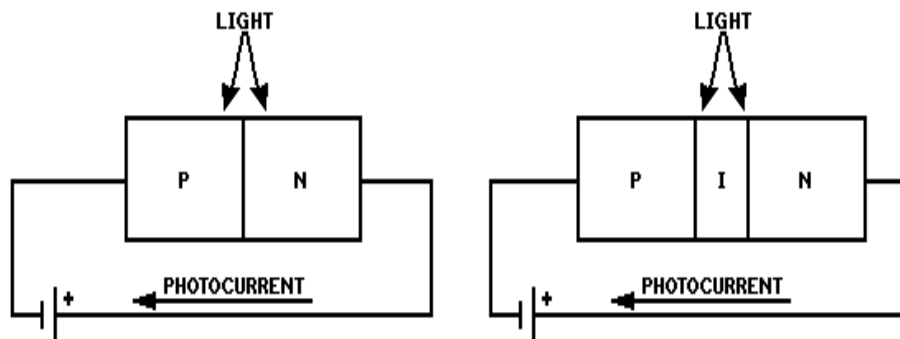

A photodiode is a specially constructed **PN** or **PIN** semiconductor diode. When radiant energy is absorbed into a reverse-biased photodiode, some of the electrons are excited enough to become current carriers. These current carriers increase the device current (photocurrent) in proportion to radiant power of the light.

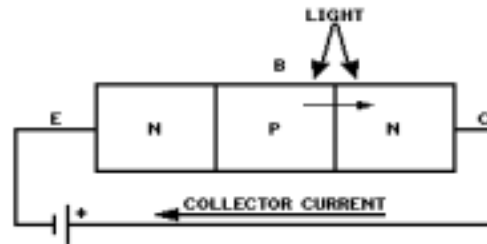

The reverse biased base-to-collector junction in a phototransistor acts as a photodiode. When exposed to radiant power it allows photocurrent to flow in the base of the transistor.

The transistor's forward current gain ( $\beta$ ) amplifies the base photocurrent. The resulting collector current is also proportional to radiant power.

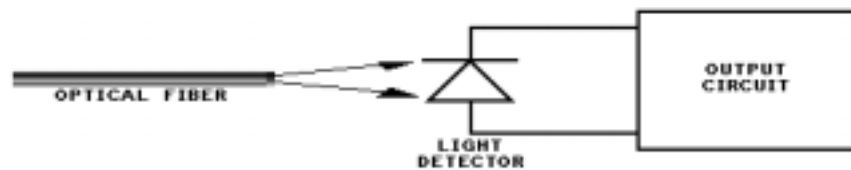

Radiant power from the optical fiber is coupled to the light detector by a fiber-to-detector connection. The fiber-to-detector connection can attenuate the radiant power reaching the light detector. The attenuation is caused by: numerical aperture (NA) mismatch, unintercepted illumination (UI), and Fresnel reflections.

**NEW TERMS AND WORDS**

**PN** - a semiconductor diode that uses two doped regions (positive-negative).

**PIN** - a semiconductor diode that uses an intrinsic (not doped) region between two doped regions (positive-intrinsic-negative).

**transducer** - a device that converts energy from one form to another.

**effective light-sensitive area** - the light-sensitive area at the surface of the optical fiber end.

**effective light-sensitive diameter** - the diameter of the effective light-sensitive area.

**responsivity ( $R_p$ )** - the ratio of an optical input transducer's electrical output to the incident radiant power.

**transimpedance amplifier** - an active circuit intended to change the impedance of a signal.

**noise floor** - (noise equivalent power) the optical signal that would produce a signal-to-noise ratio of 0 dB.

**differential amplifier** - an active circuit whose output signal is proportional to the algebraic difference between the two input signals.

**hysteresis** - a small amount of positive feedback that provides stability.

**EQUIPMENT REQUIRED**

In order to complete the following exercises, you will need:

F.A.C.E.T. base unit

FIBER OPTIC COMMUNICATIONS circuit board

Multimeter

Oscilloscope, dual trace

Generator, sine wave



## Exercise 1 – Light Detectors

### EXERCISE OBJECTIVE

When you have completed this exercise, you will be able to describe the devices used in fiber optics to convert an optical signal into an electrical signal.

### DISCUSSION

- A fiber-optic light detector has a light sensitive transducer surrounded by a shroud.
- The shroud insures that the optical fiber is the transducer's only source of radiant power.
- To prevent losses, the shroud includes a sleeve that aligns the ferrule with the light-sensitive transducer.
- The light detector is not sensitive to light that is outside its acceptance cone.
- A light detector has an acceptance angle ( $\theta_A$ ) and, therefore, a numerical aperture (NA).  

$$NA = \sin(\theta_A)$$
- If the source (fiber) numerical aperture ( $NA_1$ ) is greater than the detector's numerical aperture ( $NA_2$ ), some of the radiant power is lost ( $LOSS_{NA}$ ).  

$$LOSS_{NA} \text{ (in dB)} = 20 \times \log(NA_1/NA_2)$$
- The detector cannot sense radiant power outside its effective light-sensitive area.
- If the light diameter ( $DIA_1$ ) is greater than the effective light-sensitive diameter ( $DIA_2$ ), a loss of radiant power ( $LOSS_{UI}$ ) will occur.  

$$LOSS_{UI} \text{ (in dB)} = 20 \times \log(DIA_1/DIA_2)$$
- If the detector has a lens, the transducer's effective light-sensitive area is increased.
- Effective light-sensitive diameter ( $DIA_2$ ) is equal to the diameter of the transducer's physical sensitive area ( $DIA_p$ ) times the lens magnification ( $L_m$ ).  

$$DIA_2 = DIA_p \times L_m$$
- Responsivity ( $R_p$ ) is the ratio of the detector radiant input power ( $\phi_e$ ) and the corresponding electrical output ( $I_p$ ).  

$$R_p = I_p/\phi_e$$
- Responsivity is specified for a specific wavelength because detector sensitivity changes with wavelength.



## Exercise 2 – Receiver Output Circuits

### EXERCISE OBJECTIVE

When you have completed this exercise, you will be able to describe analog and digital circuits used to interface the light detector.

### DISCUSSION

- The receiver output circuit converts the light detector signal into a format compatible with other system components.
- The FIBER OPTIC RECEIVER (FOR) on the FIBER OPTIC COMMUNICATIONS circuit board uses a PIN photodiode.
- A transimpedance amplifier changes the high impedance photodiode output to the  $20\Omega$  FOR output.
- The entire FOR device is considered to be the light detector.
- The FOR converts changes in light power ( $D\phi_e$ ), representing the message intelligence, into voltage changes ( $D_{VOUT}$ ).
- A coupling capacitor passes voltage changes ( $D_{VOUT}$ ) to the receiver output circuit while blocking dc.
- Blocking dc at the FOR output eliminates dc bias drift.
- The analog receiver output circuit is an inverting amplifier that corrects the signal amplitude, impedance, phase, and bandwidth.
- The digital receiver output circuit is an inverting pulse detector.



## UNIT 5 – FIBER-OPTIC SYSTEMS

### UNIT OBJECTIVE

When you have completed this unit, you will be able to explain and demonstrate tests and measurements performed on fiber-optic systems and an optical power budget for a fiber-optic link. You will verify your results by using an oscilloscope, voltmeter, and visual observations.

### UNIT FUNDAMENTALS

In preparing your household budget, you begin by listing your salary and other sources of family income, and then subtract expenses such as rent, groceries, and utilities.

If your expenses are greater than your income, the budget is exceeded, and you must make adjustments accordingly.

Ideally, your income is greater than your expenses, in which case you have additional money left over for security or to use for luxury items, investment, home improvements, etc.

In much the same way, a designer uses an **optical power budget** to balance the amount of optical power applied to a fiber-optic system (the income) versus the amount consumed by system components (expenses).



In a typical fiber-optic link, a transmitter can be connected to the receiver through several fiber-optic cables connected in series as shown.

There is an optical power loss associated with each part of the link. For example, the first connector has a loss of  $L_1$ , followed by a cable loss of  $L_2$ , and so on.

The transmitter output power minus the total system losses must be greater than or equal to the minimum power required by the receiver to reliably recover an optical signal. This minimum power level is **receiver sensitivity**.

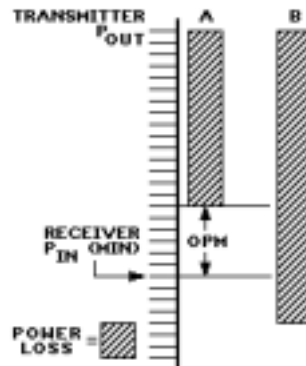

This figure shows two examples of power loss.

In example A, additional optical power remains after all losses are subtracted from the transmitter output power. The remaining power is called the **optical power margin (OPM)**.

In example B, the losses are large enough to surpass the minimum receiver input power. In this case, you would have to make adjustments to the system so the budget is not exceeded.

Another type of budget applied to fiber-optic systems is a **rise time budget**.

All components in a fiber-optic link must operate fast enough to meet the bandwidth requirements of the application.

Connectors, splices, and couplers usually do not affect system speed. Therefore, the rise time budget normally applies only to the transmitter, receiver, and fiber(s).

The system rise time equals the square root of the sum of the squares of the individual rise times, multiplied by 1.1 to allow for a 10% degradation factor of the components:

$$t_{r(\text{sys})} = 1.1[t_{r(\text{trans.})}^2 + t_{r(\text{rcvr})}^2 + t_{r(\text{fiber})}^2]^{1/2}$$

$$t_{r(\text{sys})} = 1.1[t_{r(\text{trans.})}^2 + t_{r(\text{rcvr})}^2 + t_{r(\text{fiber})}^2]^{1/2}$$

## NEW TERMS AND WORDS

**optical power budget** - the difference between the minimum transmitter power ( $P_{T\text{min}}$ ) and the input power required for a LOW output voltage ( $P_{R(L)}$ ):  $OPB = P_{T\text{min}} - P_{R(L)\text{min}}$ .

**optical power margin (OPM)** - the difference between the transmitter optical power, less system losses, and the receiver sensitivity.

**rise time budget** - a budget that ensures that the rise times of all components in a fiber optic link meet the bandwidth requirements of the application.



## Exercise 1 – Optical Power Budget

### EXERCISE OBJECTIVE

When you have completed this EXERCISE, you will be able to explain an optical power budget applied to a fiber-optic link on your circuit board. You will verify your results by using an oscilloscope and visual observations.

### DISCUSSION

- A fiber-optic transmitter outputs a certain amount of optical power into a communication link. As the light propagates to the receiver, optical power losses occur at various points along the way.
- Each coupling point (source-to-fiber, fiber-to-fiber, and fiber-to-detector) can be a source of several types of power loss.
- The mechanics of the coupling itself induce a power loss. Additional coupling losses can result from mismatches in numerical aperture and cross-sectional area if different types of cable are joined.
- The optical fibers also contribute to power loss. Every fiber has an attenuation that is a function of its length and composition.
- An OPB allows the designer to account for all expected losses in a communication link, and to ensure that the remaining power is adequate to produce a reliable signal at the receiver.
- A reliable signal is one that maintains a signal-to-noise ratio that allows a permissible bit error rate (BER).
- For each fiber, the power loss appears as a downward slope since fiber attenuation is a linear function of its length.
- Ideally, the minimum transmitter power minus the system losses is greater than the minimum power required by the receiver (receiver sensitivity). The difference between these two values is the optical power margin (OPM).
- A typical margin of 3 to 6 dB ensures that sufficient power is available at the receiver to recover a reliable signal under worst-case conditions.
- Individual losses are subtracted from the transmitter power to determine the power delivered to the receiver.



## Exercise 2 – Fiber-Optic Equipment

### EXERCISE OBJECTIVE

When you have completed this exercise, you will be able to describe the test equipment and techniques used to service fiber-optic systems.

### DISCUSSION

- Commonly used optical test equipment includes: fiber-optic light source, fiber-optic power meter, and optical time-domain reflectometer (OTDR).
- Fiber-optic light sources consist of a fiber-optic transmitter (FOT), driver circuit, and portable power supply.
- On some units the optical connector can be changed to support a variety of fiber-optic applications.
- A fiber-optic power meter consists of a light detector (FOR), calibrated output circuit, and digital display.
- The FOR receives light from the optical fiber and outputs an electrical signal.
- The output circuit scales the FOR output for the selected wavelength and outputs a signal that represents the input light power.
- The digital display shows the power measurement in dBm or  $\mu\text{W}$ .
- On some models the fiber-optic connector can be changed to support a variety of applications.
- The light source and power meter can be used to test fiber-optic cables and connectors.
- Additionally, the power meter can be used to verify power budgets by measuring system power levels.
- Optical time-domain reflectometers (OTDR) display the amplitude and timing of optical reflections.
- An OTDR consists of a beam splitter, fiber-optic receiver and transmitter, pulse circuit, and computerized display.
- The pulse circuit generates pulses which are used to drive the fiber-optic transmitter and synchronize data capture circuitry in the computerized display.
- The pulses are converted to light by the fiber-optic transmitter.
- The light pulses travel through a beam splitter and are coupled to the output connector.
- Light energy reflected by fiber imperfections is directed back to the fiber-optic receiver by the beam splitter.
- The fiber-optic receiver converts the reflected light into an electrical signal that is processed by the computerized display.
- The Y-axis on the OTDR display represents the power reflected back from the cable. The X-axis represents time.
- Using the effective index of refraction of the fiber and the speed of light in a vacuum ( $c = 300,000 \text{ km/s}$ ), time ( $t$ ) can be converted to distance ( $D$ ).





## UNIT 8 – MICROPROCESSOR INTERFACE

### UNIT OBJECTIVE

When you have completed this unit, you will be able to explain and demonstrate the transmission and reception of digital data from a microprocessor via the RS-232 port of the FIBER OPTIC COMMUNICATIONS circuit board and fiber optic cables.

### UNIT FUNDAMENTALS

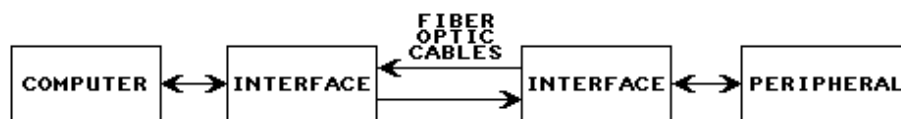

Special interfaces allow communication over a fiber-optic link between a computer and a peripheral device such as a terminal or printer. These interfaces combine RS-232 serial ports with fiber-optic systems.

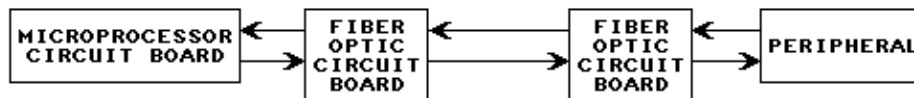

This simplified block diagram shows how two FIBER OPTIC circuit boards can be used to interface the 32-BIT MICROPROCESSOR circuit board with a PERIPHERAL.

### NEW TERMS AND WORDS

None

### EQUIPMENT REQUIRED

F.A.C.E.T. base unit  
 FIBER OPTIC COMMUNICATIONS circuit board  
 32-BIT MICROPROCESSOR circuit board  
 Oscilloscope, dual trace  
 RS-232 cable



## Exercise 1 – Serial Interface

### EXERCISE OBJECTIVE

When you have completed this Exercise, you will be able to interface the FIBER OPTIC COMMUNICATIONS circuit board with the 32-BIT MICROPROCESSOR circuit board and demonstrate the transmission and reception of microprocessor data via an RS-232 port and a fiber-optic communication link.

### DISCUSSION

- Two FIBER OPTIC COMMUNICATIONS circuit boards (A and B) can be used to interface the 32-BIT MICROPROCESSOR circuit board with a PERIPHERAL.
- The microprocessor, or CPU (central processing unit), writes and reads parallel data to and from a serial communications port. The serial port is configured as an RS-232 DTE port.
- The 32-BIT MICROPROCESSOR circuit board's SERIAL PORT communicates with the RS-232 INTERFACE on FIBER OPTIC COMMUNICATIONS circuit board A via the signals TX, RX, RTS, and CTS.
- Data from the 32-BIT MICROPROCESSOR board to FIBER OPTIC COMMUNICATIONS board A is transferred on the TX (transmit data) output.
- Data from FIBER OPTIC COMMUNICATIONS board A to the 32-BIT MICROPROCESSOR board is transferred on the RX (receive data) input.
- RTS (request to send) is a signal from the 32-BIT MICROPROCESSOR board requesting the PERIPHERAL to send its data.
- CTS (clear to send) is a signal to the 32-BIT MICROPROCESSOR board that indicates the PERIPHERAL is ready to receive data.
- These "handshaking" signals ensure cooperation between the two circuits for an efficient data transfer.
- The RS-232 INTERFACE multiplexes the TX (data) and RTS signals onto the output channel.
- The RX (data) and CTS signals are demultiplexed from the input channel.
- On FIBER OPTIC COMMUNICATIONS board A, transmitted data from the RS-232 INTERFACE is input to the DIGITAL XMITTER, which in turn drives the fiber optic transmitter (FOT).
- The FOT converts the digital signal into light pulses and transmits them via a fiber-optic cable.
- The FOR and DIGITAL RCVR in FIBER OPTIC BOARD B convert the light pulses back into digital signals.
- The data is transferred between FIBER OPTIC BOARD B and the PERIPHERAL via their RS-232 ports.
- The process is reversed when data is transferred from the PERIPHERAL back to the MICROPROCESSOR BOARD.
- In the PROCEDURE to follow, you will use one FIBER OPTIC BOARD to demonstrate the transfer of microprocessor data by looping the FOT back to the FOR. In this configuration, the microprocessor receives the same data it sends out.



## APPENDIX A – SAFETY

Safety is everyone's responsibility. All must cooperate to create the safest possible working environment. Students must be reminded of the potential for harm, given common sense safety rules, and instructed to follow the electrical safety rules.

Any environment can be hazardous when it is unfamiliar. The F.A.C.E.T. computer-based laboratory may be a new environment to some students. Instruct students in the proper use of the F.A.C.E.T. equipment and explain what behavior is expected of them in this laboratory. It is up to the instructor to provide the necessary introduction to the learning environment and the equipment. This task will prevent injury to both student and equipment.

The voltage and current used in the F.A.C.E.T. Computer-Based Laboratory are, in themselves, harmless to the normal, healthy person. However, an electrical shock coming as a surprise will be uncomfortable and may cause a reaction that could create injury. The students should be made aware of the following electrical safety rules.

1. Turn off the power before working on a circuit.
2. Always confirm that the circuit is wired correctly before turning on the power. If required, have your instructor check your circuit wiring.
3. Perform the experiments as you are instructed: do not deviate from the documentation.
4. Never touch "live" wires with your bare hands or with tools.
5. Always hold test leads by their insulated areas.
6. Be aware that some components can become very hot during operation. (However, this is not a normal condition for your F.A.C.E.T. course equipment.) Always allow time for the components to cool before proceeding to touch or remove them from the circuit.
7. Do not work without supervision. Be sure someone is nearby to shut off the power and provide first aid in case of an accident.
8. Remove power cords by the plug, not by pulling on the cord. Check for cracked or broken insulation on the cord.





